

Instructions for Continued Airworthiness

Emergency Vision Assurance System Model 107STC-XXX



MaryAnn H. Omerod

Chief Operating Officer

Master Manual, VSC Document Number: 8017

Revision 19, 29 Oct 24

VisionSafe, LLC.
P.O. Box 5011
46-217 Kahuhipa Street
Kaneohe, HI 96744
USA

Telephone: 1-800-441-9230
Web Site: www.visionsafe.com

TABLE of CONTENTS

Title	Title
Table of Contents Detail	1
Log of Revisions	2-3
List of Effective Pages	4
Reserved	5
Preface	6
1. INTRODUCTION AND GENERAL	1:2
1.1. ACCEPTANCE OF ICA MANUAL BY THE ADMINISTRATOR (REF: 14 CFR §§ 25.1529)	1:2
1.2. ARRANGEMENT AND FORMAT OF THE MANUAL (REF PART 25, APPENDIX H, H25.2 (B))	1:2
1.3. APPLICABILITY	1:4
1.4. ACRONYMS AND DEFINITIONS OF TERMS	1:6
1.5. UNITS OF MEASURE	1:7
1.6. AIR AND GROUND SHIPMENT OF EVAS®	1:7
1.7. EVAS® DESCRIPTION	1:7
1.8. TRAINING	1:10
1.9. CONTACT INFORMATION	1:10
1.10. ELECTRICAL WIRING INTERCONNECT SYSTEM (EWIS)	1:10
2. CHECKS, SERVICES AND REBUILD REQUIREMENTS	2:2
2.1. OBLIGATION TO INCORPORATE ICA MAINTENANCE INFORMATION	2:2
2.2. REMOVAL AND INSTALLATION OF EVAS®	2:3
2.3. TYPES OF CHECKS AND INSPECTIONS	2:6
2.4. REBUILD REQUIREMENTS	2:11
2.5. PILOT SMOKE EVENT REPORT (VS QC FORM 38, REV B)	2:12
3. DIMENSIONS AND ACCESS	3:2
3.1. EXPLANATION OF EVAS® FEATURES	3:2
3.2. DIMENSIONS	3:3
3.3. SPECIFICATIONS	3:3
3.4. LOCATION OF ACCESS PANELS	3:4
3.5. EVAS STORAGE	3:5
4. AIRWORTHINESS LIMITATIONS (REF: 14 CFR § 43.16 AND § 91.403)	4:1

(Remainder of page reserved.)

LOG of REVISIONS

Page 1 of 2

REV	DATE	PAGE NUMBERS	INITIAL
0	22 Nov 03	Original Issue: Title – 4:2	MHO
01	05 Apr 04	Title; TOC 3, 5, 7, 8.	MHO
02	18 Oct 05	TOC 3, 5, 7; Chapter 1: 5-6; Chapter 2: 2-4; Chapter 4: 2	MHO
03	04 Jan 06	TOC 3, 5, 7; Chapter 2: 3-4.	MHO
04	23 Mar 06	Title, TOC 1, 3, 5, 7; Chapter 2: 2-8; Chapter 3: 3	MHO
05	24 Jan 07	Title, TOC 1, 3, 5, 7-8. Chapter 1: 2, 4-8, Chapter 2: 2-9; Chapter 3: 2; Chapter 4: 2; Chapter 5: 1-5; Chapter 6: 1-5.	MHO
06	16 Apr 07	TOC 3, 5, 7; Chapter 1: 3-7; Chapter 2: 8; Chapter 3: 3.	MHO
07	25 Mar 08	Title; TOC 1, 3, 5, 7-8; Chapter 1: 2, 5-6; Chapter 2: 4-5, 7-8; Chapter 3: 2-4; Chapter 7: 1-5.	MHO
08	24 Jul 08	Title; TOC 1, 3, 5, 7, 8; Chapter 1: 4-9; Chapter 2: 7-10; Chapter 3: 3; Chapter 4: 2; Chapter 5: 1-5; Chapter 6: 1-5.	MHO
09	19 Jun 09	Title; TOC 1-2, 3, 5-8; Chapter 1: 2, 4, 7-10; Chapter 2: 1-13; Chapter 3: 3.	MHO
10	23 Dec 10	Title; TOC 1, 2, 3, 5-7; Chapter 1: 4-9, 11; Chapter 2: 3, 7-14; Chapter 3: 2; Chapter 5: 2-5; Chapter 6: 2-5; Chapter 7: 2-5; Appendix 1: 1-8.	MHO
11	25 Apr 13	TOC 5-7	MHO
12	20 Oct 15	Title; TOC: 1, 7; Chapter 2: 9-10; Appendix 1	MHO
13	28 Oct 15	Title; TOC: 1, 7; Chapter 2: 2, 7, 9, 10	MHO
14	30 Jun 16	Title; TOC: 3, 5, 6, 8; Chapter 1: 2-7, 10; Chapter 2: 3, 9, 11, 12; Chapter 4: 2; Chapter 5: 2, 3; Chapter 6: 2, 4; Chapter 7: 2, 3; Appendix 1: 2	MHO
15	1 Aug 18	Title; TOC: 1, 2, 4, 5; Chapter 1: 2-4, 10; Chapter 2: 2-11	MHO
16	1 Sep 20	Title; TOC: 1, 3; Chapter 2: 8-9; Chapter 3: 4	MHO
17	5 May 22	Title; TOC 1, 2, 4, 6; Chapter 1: 7-10; Chapter 2: 3, 2: 7-10	MHO
18	25 Jun 24	Entire Document	MHO
19	29 Oct 24	Chapter 1.4	MHO

LIST of EFFECTIVE PAGES

DESCRIPTION	PAGE	REV	DATE
Title	Title	19	29 Oct 24
Table of Contents Detail	1	19	29 Oct 24
Log of Revisions	2	19	29 Oct 24
	3	19	29 Oct 24
List of Effective Pages	4	19	29 Oct 24
Reserved	5	19	29 Oct 24
Preface	6	19	29 Oct 24
Chapter 1	1	19	29 Oct 24
	2	19	29 Oct 24
	3	19	29 Oct 24
	4	19	29 Oct 24
	5	19	29 Oct 24
	6	19	29 Oct 24
	7	19	29 Oct 24
	8	19	29 Oct 24
	9	19	29 Oct 24
	10	19	29 Oct 24
Chapter 2	1	19	29 Oct 24
	2	19	29 Oct 24
	3	19	29 Oct 24
	4	19	29 Oct 24
	5	19	29 Oct 24
	6	19	29 Oct 24
	7	19	29 Oct 24
	8	19	29 Oct 24
	9	19	29 Oct 24
	10	19	29 Oct 24
	11	19	29 Oct 24
	12	19	29 Oct 24
	13	19	29 Oct 24
Chapter 3	1	19	29 Oct 24
	2	19	29 Oct 24
	3	19	29 Oct 24
	4	19	29 Oct 24
Chapter 4	1	19	29 Oct 24
	2	19	29 Oct 24

(Remainder of page reserved.)

PREFACE

Goal and Purpose

This document is the Instructions for Continued Airworthiness (ICA) manual for the Emergency Vision Assurance System (EVAS®) as currently manufactured by VisionSafe, LLC.

The **Goal** of this manual is to provide complete, correct and current instructions for the continued airworthiness of EVAS®. The instructions are in accordance with the requirements specified in Appendix H to 14 CFR Part 25, and other such items which are not specifically required by 14 CFR but are needed to ensure that the instructions are complete, correct and current for continued airworthiness of EVAS®.

The **Purpose** of this manual is to serve as a reference document to users for the on-going maintenance and servicing of EVAS®.

Compliance

VisionSafe, LLC (VSC) staff, Aircraft Maintenance Technicians (AMTs), repair stations and other agencies providing aviation maintenance and servicing for EVAS® are required to conduct those operations in a safe, responsible manner and to comply with applicable CFR's and professional standards. Awareness and compliance with the ICA in this manual is mandatory.

Quality and Continuous Improvement

Care has been used in the preparation and distribution of the manual. However, should any perceived conflict arise between portions of this manual and any CFR's or professional standard, such conflicts shall be reported and brought to my attention for formal resolution.

Finally, all users should regard this manual as an integral part of a continuous improvement process. Your recommendations for improvement are welcome.

MaryAnn H. Omerod

MaryAnn H. Omerod
Chief Operating Officer
VisionSafe, LLC

CHAPTER 1

INTRODUCTION

1 INTRODUCTION AND GENERAL

This chapter contains information of an introductory and general nature about EVAS®. The conventions and format used throughout the manual are also presented.

1.1 ACCEPTANCE OF ICA MANUAL BY THE ADMINISTRATOR (REF: 14 CFR §§ 25.1529)

VSC has prepared this manual to provide the Instructions for Continued Airworthiness (ICA) of the Emergency Vision Assurance System (EVAS®). The ICA are in accordance with (IAW) the applicable requirements specified in Appendix H to 14 CFR Part 25.

This ICA manual is reviewed and accepted by the Aircraft Evaluation Division (AED) of the Federal Aviation Administration (FAA).

1.2 ARRANGEMENT AND FORMAT OF THE MANUAL (REF: PART 25, APPENDIX H, H25.2 (B))

Information presented in this manual is DIRECTIVE in nature. Information and work instructions are arranged by Chapter and major / minor subjects within chapters. A decimal system of numbering allows for organization and cross referencing.

Each Chapter, Section, and Subsection is designated by title and Arabic numeral. All numbering breakdowns are arranged according to a decimal sequence.

- 1 Chapter The first number enumerates the Chapter.
- 1.1 Section The second number enumerates the Section.
- 1.1.1 Subsection The third number enumerates the Subsection.
- 1.1.1.1 Subsection The fourth number enumerates an additional Subsection, etc.
- 1) then a) or • Series Lettering..... Items listed in series under the sections are enumerated as a numeric list then an alphabetic list or as bullets.

This system provides a simple method of referral and cross reference to material in this manual. The symbol “§” is used to indicate the prefix "Section" or "Subsection." For example, the notation § 1.1.2.5 is read as subsection 1.1.2.5 (or conversationally, section 1.1.2.5). Likewise, §§ 3.2.3 – 3.2.8 (or written as 3.2.3 – 8) is read as “sections 3.2.3 through 3.2.8 ;” or more simply, §§ is the plural form of §.

1.2.1 PAGINATION, REVISION CONTROL AND GENERAL

Pagination

All chapters are numbered sequentially. The chapter number and chapter name are in the middle portion of the footer. The page numbers are in the right portion of the footer. The page numbering format is "chapter number: page number." Thus, page 1:2 is read as chapter 1, page 2.

Revision Control

The version or revision control of all pages is indicated in the lower left corner of all pages. For example, "Original, 22 Nov 03" indicates an original page dated 22 Nov 03. If that page is subsequently revised on 24 May 04 for example, the page would be marked "Rev 01, 24 May 04 and the List of Effective Pages would be updated accordingly.

Revision Mark

Material added or revised in the manual will be marked with a vertical bar in the margin area to indicate where the newly added or revised material is located. Minor editorial changes, spelling corrections and text deletions are not normally marked. All revision marks are removed at the next revision.

Validity of Manual Content

Any statements in this manual found to be illegal, incorrect, and/or inapplicable shall not affect the validity of the remaining content.

Titles in the manual shall not govern, limit, modify or affect the scope, meaning or intent of any volume, chapter, section or subsections of this manual.

Grammatical Construction

The content of the manual shall be interpreted using the grammatical rules below.

- Tense The present tense also includes the past and future.
- Gender The masculine also includes the feminine where appropriate.
- Singular and plural The singular also includes the plural.
- Mandatory and permissive "Shall" is mandatory, "may" is permissive.

Printing

The printed version of this manual is normally single-sided. Other printing formats are provided depending on customer needs.

When there is no written text for a numbered page, the page shall contain the statement:

(This page intentionally blank.)

When the lower portion of a page is reserved for future use, the page shall contain the statement:

(Remainder of page reserved.)

1.2.2 REVISION PROCEDURE

Revisions are prepared by VSC and distribution to manual holders is done via an email notification.

At any time, manual holders may also download and print out a complete and current ICA manual via the VisionSafe website. The manual can be found in multiple locations throughout the website at: www.visionsafe.com

1.3 APPLICABILITY

This ICA manual applies to all EVAS® model 107STC-XXX.

EVAS® model 107STC-XXX is an appliance or part (see definitions in § 1.4). VSC, manufacturers of EVAS®, identify or name the EVAS® appliance as "EVAS® model 107STC-XXX." The dash XXX suffix is a placeholder for a number suffix used by VSC to identify four (4) additional characteristics of EVAS®:

- The aircraft model for which EVAS® may be installed and used.
- The particular IVU associated with a particular EVAS®.
- The seat specific location (left seat or right seat).
- The type of attachment bracket or side plate to be used with this appliance in any particular installation. (see § 2.3.1)

Each pair of EVAS® (one left seat and one right seat) will have consecutive dash numbers, with the left seat EVAS® being an odd number, and the right seat EVAS® being the left seat number +1.

An ICA manual is required by regulation for each appliance IAW the following references:

- 14 CFR Part 25 Appendix H, H25.1(b)

VSC produces only one appliance and that one appliance is designated as EVAS® Model 107STC-XXX. Since this one appliance is already covered by this ICA manual there is no need for additional ICA manuals.

(Remainder of page reserved.)

1.3.1 ADDITIONAL INFORMATION CONCERNING APPLICABILITY

Although this manual applies to all EVAS® model 107STC-XXX units, readers who require additional identifying information should consult the following table.

Information Desired	Document Location Information
EVAS® model vs. aircraft model	The EVAS® Model Eligibility List is a controlled document and is maintained by VisionSafe, LLC, manufacturer of EVAS®. The complete document can be found on the company website.
Specific location of EVAS® in aircraft	To view the installation drawing containing the location of the EVAS® unit for your specific aircraft, please visit the Client Access Portal on the company website. The specific aircraft links in this area are password protected for Proprietary reasons. Please consult your Packing List that accompanies your units for login and password information. If you require assistance for this area, please contact qcontrol@visionsafe.com .
AFMS vs. aircraft model	To view the AFMS for your specific aircraft, please visit the Client Access Portal on the company website. The specific aircraft links in this area are password protected for Proprietary reasons. Please consult your Packing List that accompanies your units for login and password information. If you require assistance for this area, please contact qcontrol@visionsafe.com .

(Remainder of page reserved.)

1.4 ACRONYMS AND DEFINITIONS OF TERMS

§	The symbol “§” is used to indicate the prefix Section or Sub-subsection. For example, the notation § 1.1.2.5 is read as Sub-section 1.1.2.5 (or conversationally, section 1.1.2.5 .). Likewise, §§ 3.2.3 – 3.2.8 (or as 3.2.3 – 8) is read as “sections 3.2.3 through 3.2.8 ;” or more simply, §§ is the plural form of §.
AED	Aircraft Evaluation Division
AMT	Aircraft Maintenance Technician. An AMT is an FAA (or other equivalent aviation agency) certificated aircraft maintenance technician.
ALS	Airworthiness Limitations Section.
Appliance	Appliance means any instrument, mechanism, equipment, part, apparatus, appurtenance, or accessory, including communications equipment, that is used or intended to be used in operating or controlling an aircraft in flight, is installed in or attached to the aircraft, and is not part of an airframe, engine, or propeller. Avionics equipment is an appliance.
EVAS®	EVAS® is an acronym for “Emergency Vision Assurance System.”
FAA	Federal Aviation Administration.
CFR	Code of Federal Regulations.
IAW	Means "in accordance with."
ICA	Instructions for continuing airworthiness.
IVU	Inflatable Vision Unit. The inflated portion of EVAS® that allows the pilot to see outside and see the primary flight instruments.
STC	Supplemental Type Certificate. An STC is issued for major design changes to a TC when the change is not so extensive as to require a new TC (ref: 14 CFR § 21.19). Minor changes do not require an STC. Minor and major changes are classified in 14 CFR § 21.93. <i>Ref: Order 8110.4B</i>
VSC	VisionSafe, LLC, the manufacturer of EVAS®. VisionSafe

(Remainder of page reserved.)

1.5 UNITS OF MEASURE

The units of measure for EVAS[®] is the US System of Measurement.

1.6 AIR AND GROUND SHIPMENT OF EVAS[®]

The EVAS[®] unit, including the internal battery pack, is not subject to the requirements of Title 49 CFR – 172.101 Hazardous Materials Requirements. However, EVAS[®] units are subject to Title 49 CFR Part 172.102, Provision 130 which requires compliance with the following three items when transported by aircraft, for a battery whose voltage (electrical potential) exceeds 9 volts:

- 1) The sender must securely package the EVAS[®] units. Secure packaging means that the EVAS[®] unit is cushioned within the shipping package so as to prevent excessive movement.
- 2) When contained in a device, the device must be packaged in a manner that prevents unintentional activation or must have an independent means of preventing unintentional activation (e.g., packaging restricts access to activation switch, switch caps or locks, recessed switches, trigger locks, temperature sensitive circuit breakers, etc.).
- 3) An indication of compliance with this special provision must be provided by marking each package with the words "not restricted" or by including the words "not restricted" on a transport document such as an air waybill accompanying the shipment.

1.7 EVAS[®] DESCRIPTION

EVAS[®] is an acronym for "Emergency Vision Assurance System." EVAS[®] is a stand-alone, self-contained system that requires no integration into any existing aircraft systems and does not introduce any new wiring into the aircraft.

EVAS[®] includes a battery powered blower which draws smoky air in through a filter, filtering out the visible particles, and out to a flexible air duct, which is connected to an inflatable transparent envelope, called the "Inflatable Vision Unit," (or IVU). The entire EVAS[®] system is contained in an aluminum container that is approximately the size of a Jeppesen manual and weighs approximately 6 pounds.

The pilot deploys EVAS[®] by first removing the cover from the EVAS[®] container. With the EVAS[®] container open, the pilot inserts his hand into the EVAS[®] container and removes the IVU from the container and places the entire IVU package onto a strip of loop fastener installed on the glare shield. Removal of the IVU package from the container pulls a lanyard, closing the lanyard switch, thereby automatically starting the blower and switching the internal IVU light ON.

As soon as vision assistance is needed, the pilot must hold the IVU in place on the glare shield with one hand and release the IVU for inflation by firmly pulling on the tab of the restraining strap with his other hand. As the IVU inflates, assist inflation by gently unfolding the IVU envelope and positioning the windshield portion and the instrument panel portion for optimum vision. Be sure to assist the instrument portion of the IVU so it inflates between the control wheel and the instruments.

While in use, EVAS® will inflate the IVU with filtered, clear air at a pressure slightly above that of ambient air, thus completely displacing all smoke from the volume of the IVU. As the IVU is transparent, this gives the pilot a clear vision path to the essential flight instruments and forward along the flight path. The internal IVU light is fixed within the IVU and remains on at all times to provide added illumination of the flight instruments.

(See also § 3.1)

1.7.1 FEATURES AND PRINCIPLES OF OPERATION

- 1) EVAS® displaces all smoke in the vision path, regardless of density.
- 2) EVAS® provides clear vision of basic instruments and flight path, and lights instruments.
- 3) EVAS® allows limited use of check lists, approach charts, etc.
- 4) EVAS® provides continuous operation for several hours. Intermittent operation conserves power and provides satisfactory performance for a more extended period.
- 5) EVAS® is self-contained and independent of all aircraft systems.

(See also § 3.1.1)

EVAS® is for emergency use only. Unintentional, accidental or emergency deployment of EVAS® (IVU inflated) will require that the unit be returned to VSC for a special inspection (see § 2.3.5).

(Remainder of page reserved.)

1.7.2 PHOTOGRAPHS OF EVAS®



EVAS®, left (red) and right (green) containers.



EVAS® deployed, left side in smoke.

(Remainder of page reserved.)

1.8 TRAINING

Training options for EVAS® are described on the "Training" tab of the EVAS® website, www.visionsafe.com. Included on the training page are the EVAS® training video and multiple training options. VSC document 8015, "EVAS® Training Outline," is also available on this page.

1.9 CONTACT INFORMATION

Address: VisionSafe, LLC
46-217 Kahuhipa Street
Kaneohe, Hawaii 96744

Phone: 1 (800) 441-9230
Email: info@visionsafe.com
Website: www.visionsafe.com

1.10 ELECTRICAL WIRING INTERCONNECT SYSTEM (EWIS)

The modification has been reviewed per the guidance provided in FAA AC 25-27A. The VisionSafe EVAS system installation is completely self-contained and does not interface with the aircraft electrical system. It has been determined that the modification does not necessitate a revision to the EWIS ICA that were required to be developed by 26.11(b) / 25.1729. Therefore, the instructions contained in the aircraft level EWIS ICA are not affected and must be followed.

End of Chapter 1

CHAPTER 2

CHECKS, SERVICES AND REBUILD REQUIREMENTS

2 CHECKS, SERVICES AND REBUILD REQUIREMENTS

This chapter provides the checks, services and rebuild requirements for EVAS® Model 107STC-XXX. Incorporation of this chapter into the operator's maintenance program is required. See "obligation statement" below.

There are no field servicing requirements for EVAS®. The battery pack cannot be replaced by the customer.

2.1 OBLIGATION TO INCORPORATE ICA MAINTENANCE INFORMATION

Modification of an aircraft by a Supplemental Type Certificate for EVAS® obligates the aircraft operator to include the maintenance information provided by this ICA manual in the operator's Aircraft Maintenance Manual and the operator's Aircraft Scheduled Maintenance Program.

- 1) Maintenance Manual information (system description, operation, location, removal, installation, testing, etc.) is contained in this ICA Manual (VSC Document number 8017) and should be placed into the operators appropriate Aircraft Maintenance Manual.
- 2) EVAS® part numbers and other necessary part numbers contained in the installation data package should be placed into the aircraft operators appropriate airplane Illustrated Parts Catalog (IPC).
- 3) Scheduled Maintenance Program tasks to be added to the aircraft operators appropriate airplane maintenance program are as follows:

Prescribed scheduled checks and services include the following:

Position and Location check	see § 2.3.1
Blower and Battery check	see § 2.3.2
Loop Fastener Verification	see § 2.3.3
Biennial Service	see § 2.3.4
Special Inspection (as needed)	see § 2.3.5
120 Month Rebuild.....	see § 2.4

The items above may appear as part of opportunity inspections or recommended Zonal inspection tasks.

(Remainder of page reserved.)

2.2. REMOVAL AND INSTALLATION

2.2.1. Reference Documents

DOCUMENT TITLE	DOCUMENT NUMBER
Drawing – Installation EVAS 107STC-XXX	6XXX

The installation and removal of the EVAS units are performed using the applicable installation drawings defined in the Master Drawing Lists as listed on STC ST00731LA, ST01012WI, ST01057WI, SA01050WI, and STC ST00892LA Approved Model List.

NOTE:

During the removal and reinstallation of EVAS units for routine and non-routing maintenance, EVAS mounting locations should be visually inspected for missing, loose, or worn hardware; corroded, or cracked parts, and delamination's. Any discrepancies noted should be corrected prior to reinstalling the EVAS unit.

To view the current installation drawing of the EVAS® unit for your specific aircraft, please visit the [Client Access Portal](#) on the company website. The specific aircraft links in this area are password protected for Proprietary reasons. Please consult your Packing List that accompanies your units for login and password information. If you require assistance for this area, please contact gcontrol@visionsafe.com.

2.2.2. Two Basic Types of Installations

2.2.2.1. Direct Mount

EVAS is mounted directly to the airplane structure or instrument console using two or more fasteners. (Figure 1)

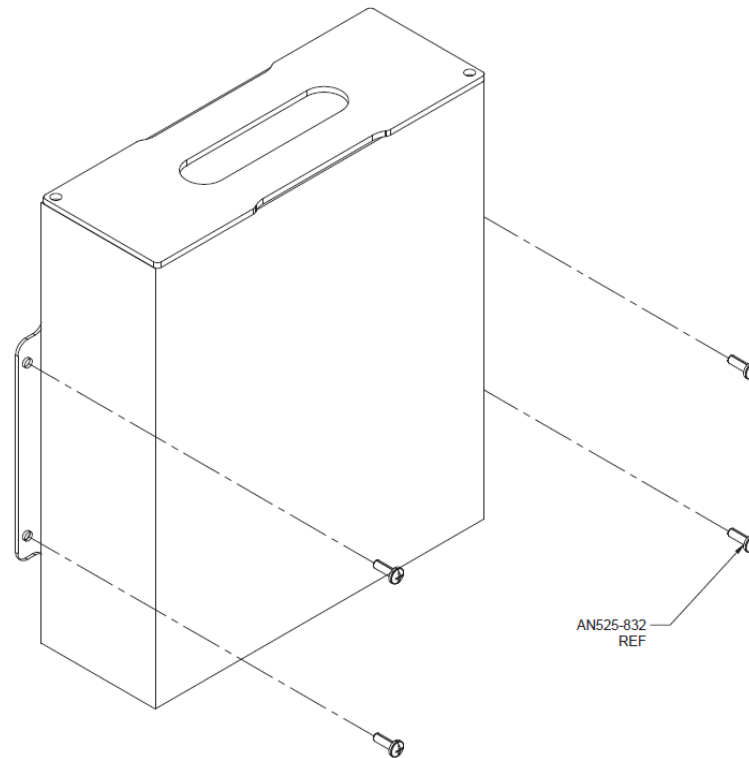

Figure 1

2.2.2.2. Rail Mount

A mounting rail is attached to the airplane structure or instrument console allowing for ease of installation and removal. The EVAS unit is slid into the mounting rail and secured into place with top mounted fasteners. (Figure 2)

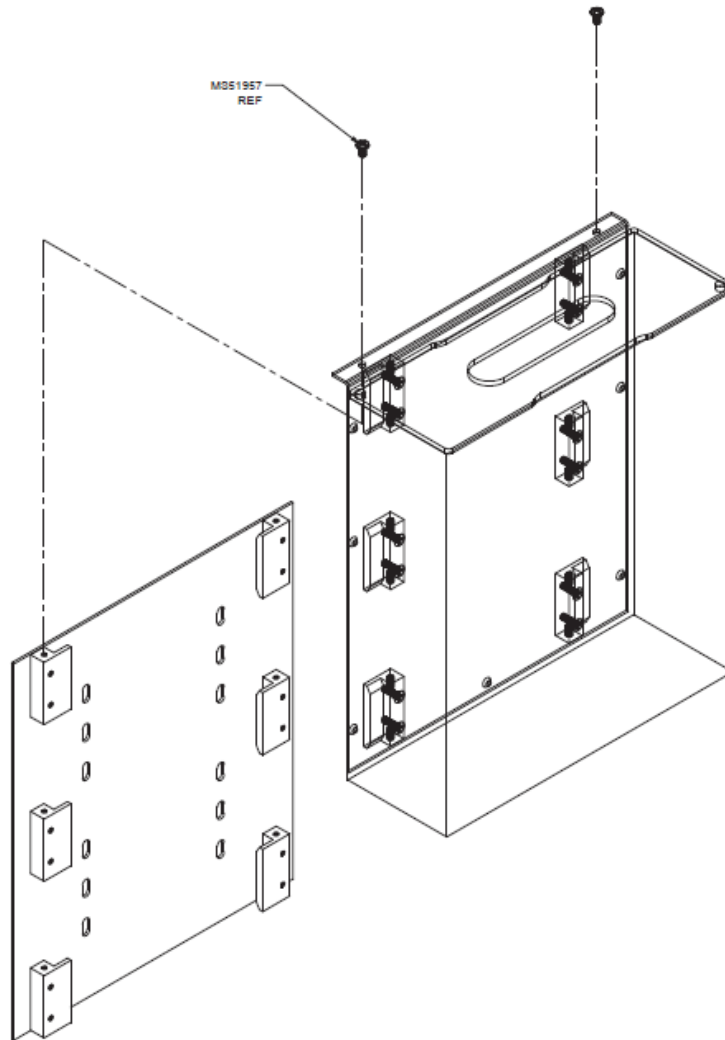

Figure 2

(This page intentionally blank.)

2.3 TYPES OF CHECKS AND INSPECTIONS

There are three (3) prescribed operator checks and three prescribed manufacturer services as listed below:

Checks and Inspections		Performing Agent
1	Position and Location check.	Aircraft owner, operator, or designee.
2	Blower and Battery check.	Aircraft owner, operator, or designee.
3	Loop Fastener Verification.	Aircraft owner, operator, or designee.
4	Biennial service.	VisionSafe, LLC (OEM).
5	Special inspection.	VisionSafe, LLC (OEM).
6	120 Month Rebuild.	VisionSafe, LLC (OEM).

2.3.1 POSITION AND LOCATION CHECK

The Position and Location Check of EVAS® is performed at regular intervals not to exceed ninety (90) days.

2.3.1.1 SCOPE OF POSITION AND LOCATION CHECK

- 1) No tools or equipment are required to accomplish the check.
- 2) In most aircraft EVAS® is located along the cockpit sidewalls or center pedestal area and within easy reach of the pilots.
- 3) Visually check EVAS® for general condition, security and proper position in the cockpit. EVAS® is seat position specific and must be installed in the proper position, i.e., the EVAS® marked "Position: Left" shall be installed or otherwise available for use on the left (pilot) side of the cockpit, and likewise the EVAS® marked "Position: Right" shall be installed or otherwise available for use on the right (copilot) side of the cockpit.

Note: To make the proper position of EVAS® in the cockpit more visually apparent, new or serviced EVAS® units have a color-coded label on the cover strap. Red indicates the left (pilot) side position; green indicates the right (copilot) side position. See sample color coded labels on the following page.

(Remainder of page reserved.)

2.3.1.2 SAMPLE COLOR CODED LABELS

One red or one green label is attached to the cover strap on the top of each EVAS[®] unit. The color coding is used to make the proper position of EVAS[®] in the cockpit more visually apparent.

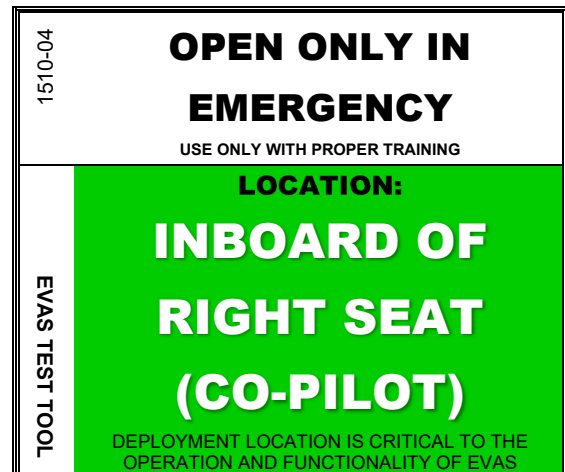
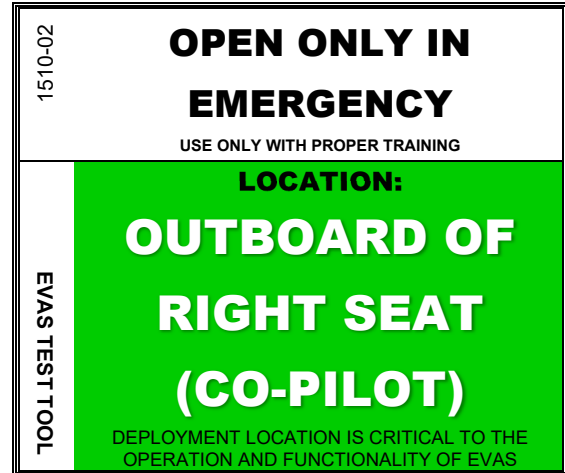

(Remainder of page reserved.)

2.3.2 BLOWER AND BATTERY CHECK, NOT TO EXCEED NINETY (90) DAYS

Depress the blower and battery test buttons simultaneously as detailed below, at regular intervals not to exceed ninety (90) days.

NOTES:

1. Except for following, the EVAS blower and battery check can be performed in the current installed location;
 - a. EVAS model 107STC-241/-242 must be removed from their mounting location in order to access the blower and battery test buttons and view the test lights.
 - b. EVAS model 107STC-167/-168 models include a pad attached by means of hook and loop fastener to the front of the container. The LH side of the pad must be released to access the blower and battery test buttons and view the test lights.
2. An inspection mirror may be used to view test lights during the blower and battery test

2.3.2.1 SCOPE OF BLOWER AND BATTERY CHECK

In addition to those items listed in § 2.3.1.1, the Blower and Battery check includes a combined check as detailed in the procedures that follow.

NOTE

EVAS[®] is shipped with the Master power switch in the ON position.

- 1) New EVAS[®] units are shipped with a small EVAS[®] test tool (effective 01 July 2009). This tool has two blunt tips used to accomplish the Blower and Battery check. The tool is stored inside the label on the top of each EVAS[®] unit. Other "tools" that may be used are hex keys, ball point pens or other equivalent tools. (see Figure 3)
- 2) Insert a blunt tipped tool into the "**Blower**" test hole and into the "**Battery**" test hole simultaneously. Push to test for approximately one to three seconds. The test instrument(s) need to be perpendicular to unit surface to fully depress the two test buttons. With the two test buttons depressed, the blower motor should be heard if performed in a noise free environment. If the blower motor is heard, the blower motor is serviceable. (see Figure 4)

Confirm which test light illuminates. A **green** "Battery Condition" light in the lower corner of the EVAS[®] container indicates that the battery condition is "GOOD," i.e., EVAS[®] is fully serviceable. If instead the **yellow** light is illuminated, the EVAS[®] unit must be removed and replaced within ten (10) calendar days. Illumination of the red "Inop" light, or no light illuminated, indicates an unacceptable battery condition. In this case, EVAS[®] must be removed from the aircraft immediately. EVAS[®] units removed from the aircraft for either a yellow or red test light, or no light, must be returned to VSC for a Special Inspection. (see § 2.3.5) (see Figure 4)

After noting the above conditions, the test may be terminated by removing the "tools" from the test holes. The tool(s) should be stored back into the RH or LH EVAS[®] label.

In the event the blower motor does not run, EVAS® is inoperable. Contact VSC Quality Assurance Department via telephone (1-800-441-9230 or 808-235-0849) or e-mail (qcontrol@visionsafe.com) as soon as practical for further instructions and test procedures.



Figure 3



Figure 4

2.3.3 LOOP FASTENER VERIFICATION, NOT TO EXCEED NINETY (90) DAYS

Verify loop fastener(s) are secured on glare shield. Re-attach or replace as required using epoxy adhesive per VisionSafe Process Specification 8110. Specific instructions for each model can be found on the installation drawings.

2.3.4 BIENNIAL SERVICE

The biennial service is performed every 24 months \pm 3 months by VSC IAW VS TC-Form 1, Service. The timing of the first Biennial Service is based upon the manufacture date as provided on the documentation accompanying a new EVAS[®] unit and as engraved on the container of units manufactured after 01 April 06. The first inspection due date is the Service Due date printed on the EVAS[®] container. This service includes replacing the EVAS[®] battery pack; this cannot be accomplished by the customer. The service may also include applicable upgrades by VSC.

Thus, EVAS[®] customers must plan to remove their EVAS[®] units from the aircraft at a convenient time and ship the EVAS[®] units to VSC for servicing. After servicing by VSC, the engraved year is covered with a new sticker indicating the next service due date.

The Base Service Due date is printed on the EVAS[®] container. The biennial service may be performed 3 calendar months before and up to 3 calendar months after the Service Due Date printed on the EVAS[®] container. Regardless of when this service is performed the next servicing date shall be due 24 months after the original service due date.

If the EVAS[®] unit is in for servicing before or after the 3 calendar month grace period, the base service date will be changed according to the new ship date plus two years. EVAS[®] units may be subject to additional service fees if received more than three (3) months past the base service date.

2.3.5 SPECIAL INSPECTION

A special inspection is required immediately after:

- 1) Any use or deployment of EVAS[®]. This includes any unintentional, accidental or emergency deployment of EVAS[®] (IVU inflated);

Emergency Deployment

If EVAS[®] is deployed in an emergency, please contact VSC Quality Assurance Department as soon as practical at 1-800-441-9230.

Please complete the Pilot Smoke Event Report (VS QC Form 38) for all emergency deployments. The form is available at the end of this chapter or on the Service page of the VSC website. After completion, send to VSC Quality Assurance Department. The report is requested by VSC for product improvement. All information will be treated as **Confidential and Proprietary** data.

- 2) The integrity of the EVAS[®] container or contents are compromised. Examples of integrity compromise include a dented container, immersion of EVAS[®] in any liquid and/or spillage or accumulation, or suspected accumulation, of any liquid or contaminant into the interior of EVAS[®]; and
- 3) Any test in which the "Battery Condition" status indicates "Inop," i.e., illumination of the red test light, or no light.

Special inspections may only be performed by VSC.

2.4 120 MONTH REBUILD

Rebuild of EVAS[®] is performed every 120 months \pm 3 months by VSC IAW VS TC-Form 1, Service. The timing of the first rebuild is based upon the manufacture date as provided on the documentation accompanying a new EVAS[®] unit and as engraved on the container of units manufactured after 01 April 06.

EVAS[®] customers must plan to remove their EVAS[®] units from the aircraft at a convenient time and ship the EVAS[®] units to VSC. The 120 month rebuild includes replacing most major parts, in addition to performing the Biennial Service; this cannot be accomplished by the customer.

2.5 PILOT SMOKE EVENT REPORT (VS QC FORM 38, REV B)

Please complete this report if an EVAS™ unit is deployed in an emergency situation. The form may be completed by the pilot or other personnel familiar with the incident. Mail to VisionSafe, LLC Quality Assurance, 46-217 Kahuhipa Street, Kaneohe, HI 96744; or fax it to 808-247-6313; or email it to <gcontrol@visionsafe.com>. We appreciate your assistance.

Aircraft Model	Registration	S/N	Date of Incident	From	To

CONDITIONS - Circle all that apply:

Lighting	Flight Conditions	WX Conditions	Phase of Flight w/ Smoke, all that apply	
Dawn	VMC or IMC	Xwind	Parked / Start	Holding
Daylight	Above cloud	Turbulence	Taxi	Approach
Dusk	In cloud	Windshear	Takeoff	Missed Approach
Night	Below cloud	Restricted Vis.	Climb	Landing
	Between layers	Rain Hail Snow	Cruise	Taxi
	No cloud	Fog Haze Smoke	Descent	Shutdown / Parked
		Thunderstorm		
	Single Pilot	None		
	Two Pilot	Other?		

Description of the Smoke Incident: What caused the smoke?, How soon was EVAS™ deployed?, Did both pilots deploy?, Was the IVU(s) inflated? When?, How long was the IVU(s) in use (inflated)? Was the aircraft landed using EVAS™?

.....

.....

.....

If necessary, continue on back of sheet.

Training

- 1) What EVAS™ training have the pilots received?
- 2) Frequency of EVAS™ training and last training dates?
- 3) Are you interested in further training?

Additional comments

Your name and title:			
Company name:			
E-mail address and telephone:			
Questions concerning this report can be addressed to VSC Quality Assurance, 808-235-0849 x 22, or via email to < gcontrol@visionsafe.com >. All information is <i>Confidential and Proprietary</i> .			
Line below is for VSC use only			
EVAS s/n:	EVAS s/n:	ITR #:	Servo #:

(This page intentionally blank.)

End of Chapter 2

CHAPTER 3

DIMENSIONS AND ACCESS

3 DIMENSIONS AND ACCESS

3.1 EXPLANATION OF EVAS[®] FEATURES

EVAS[®] is an acronym for "Emergency Vision Assurance System." EVAS[®] is a stand-alone, self-contained system that requires no integration into any existing aircraft systems and does not introduce any new wiring into the aircraft.

EVAS[®] includes a battery powered blower which draws smoky air in through a filter, filtering out the visible particles, and out to a flexible air duct, which is connected to an inflatable transparent envelope, called the "Inflatable Vision Unit," (or IVU). The entire EVAS[®] system is contained in an aluminum container that is approximately the size of a Jeppesen manual and weighs approximately 6 pounds.

The pilot deploys EVAS[®] by first removing the cover from the EVAS[®] container. With the EVAS[®] container open, the pilot inserts his hand into the EVAS[®] container and removes the IVU from the container and places the entire IVU package on the glare shield. Removal of the IVU package from the container pulls a lanyard, closing the lanyard switch, thereby automatically starting the blower and switching the internal light ON.

As soon as vision assistance is needed, the pilot must hold the IVU in place on the glare shield with one hand and release the IVU for inflation by firmly pulling on the tab of the restraining strap with his other hand. As the IVU inflates, assist inflation by gently unfolding the IVU envelope and positioning the windshield portion and the instrument panel portion for optimum vision. Be sure to assist the instrument portion of the IVU so it inflates between the control wheel and the instruments.

While in use, EVAS[®] will inflate the IVU with filtered, clear air at a pressure slightly above that of ambient air, thus completely displacing all smoke from the volume of the IVU. As the IVU is transparent, this gives the pilot a clear vision path to the essential flight instruments and forward along the flight path. The internal IVU light is fixed within the IVU and remains on at all times to provide added illumination of the flight instruments.

(See also § 1.7)

3.1.1 FEATURES AND PRINCIPLES OF OPERATION

- 1) EVAS[®] displaces all smoke in the vision path, regardless of density.
- 2) EVAS[®] provides clear vision of basic instruments and flight path, and lights instruments.
- 3) EVAS[®] allows limited use of check lists, approach charts, etc.
- 4) EVAS[®] provides continuous operation for several hours. Intermittent operation conserves power and provides satisfactory performance for a more extended period.
- 5) EVAS[®] is self-contained and independent of all aircraft systems.

(See also § 1.7.1)

(Remainder of page reserved.)

3.2 DIMENSIONS

Height..... 10.0 inches
 Width..... 8.5 inches
 Depth..... 3.0 inches

See photograph at right.

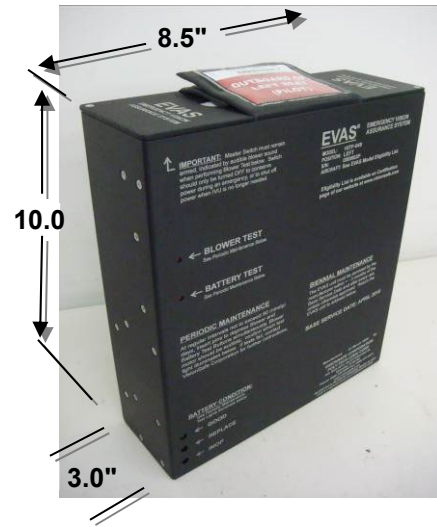

3.3 SPECIFICATIONS

Center of gravity..... 4.375 inches from bottom.

Weight..... 6 lbs (nominal). Refer to AFM for weight and balance calculation.

Materials..... Outer container: aluminum, black anodized.
 IVU: Flame retardant rip-stop nylon and Teflon.

Inflation time of IVU..... 30 to 60 seconds (nominal).

Blower parameters..... 12v DC.
 Brushless.
 Electronically commutated.
 Aluminum die cast housing.
 Permanently-lubricated ball bearings.

Maximum operating time..... 4 hours (nominal).

Rated operating time..... 2.5 hours (nominal).

Internal IVU air pressure 2.8 inches water pressure.

Filter parameters..... 0.1 micron particles – 99% efficiency.
 0.3 micron particles – 99.97 % efficiency.

Battery Pack..... +/-13.5V, 3V, 2.8Ah, alkaline.

Explosive atmosphere testing No explosive events. Satisfactory operation in all respects.

3.4 LOCATION OF ACCESS PANELS

There are no access panels for inspection or servicing of EVAS®.

3.5 EVAS STORAGE

Store EVAS units in a clean, dry environment.

End of Chapter 3

CHAPTER 4

AIRWORTHINESS LIMITATIONS

4 AIRWORTHINESS LIMITATIONS (REF: 14 CFR § 43.16 AND § 91.403)

The Airworthiness Limitations section is FAA approved and specifies maintenance required under § 43.16 and § 91.403 of the Code of Federal Regulations, Title 14, unless an alternative program has been FAA approved.

No airworthiness limitations are associated with this type design change. Formal FAA approval on this page is only needed if Airworthiness Limitations are identified. The fact that there are none is accepted by the FAA with acceptance of this manual.

End of Chapter 4